



704-734-5100

## CCS LOFT PLUS Pillow and Cushion Filling Systems

The Card Clothing Services, Inc. manufactures a complete line of **LOFT PLUS** Pillow and Cushion Filling systems. The popular System E, System 1 and System 2 are modular product lines that are able to expand with your production requirements. The CCS fiber reserve feed hopper and fiber opener is designed to maximize the fiber opening, filling power and loft memory. This is meant to produce a finish product with the least amount of fiber yet the most loft and surface uniformity in the industry.

The **LOFT PLUS System E** is our most popular Pillow and Cushion filling system. This system is capable of providing fully open fiber at the rate of approximately 150 to 250 pounds per hour. The System E consists of a horizontal or vertical high speed opener, fiber stuffing fans and electrical control. This system includes a feed conveyor that allows the operator to insert a large amount of raw material into the feed conveyor thus reducing the labor requirement. Once the feed conveyor is full of raw material, the operator slides a tick on the stuffing nozzle and step on the foot switch. The timer on the electrical control panel will establish the amount of fiber being inserted in the tick.



CCS offers many options such as multiple operator fiber filling stations, weigh system, timed feed controls, bar coding, variable speed motor drives, metal detection and humidification. Some custom systems are capable of producing as much as 3,000 pounds per hour. These systems generally include complete bale breakers that further reduce the labor requirement.

[www.cardclothingservices.com](http://www.cardclothingservices.com)

704-734-5100

### Specifications

- ~ Length: 7' 2"
- ~ Width: 5'8"
- ~ Height: 6'
- ~ Weight: 2,500 lbs.
- ~ Voltage: As Required

### Capacity

- ~ System E (one fan) - 150 to 250 lbs. per hr.
- ~ Some custom systems - up to 3,000 lbs. per hour

### Options

- ~ Single or dual nozzles
- ~ DC or AC inverter feed roll and lift apron drive
- ~ Bar Code Recipe Management
- ~ Timed feed control (on single fan systems)
- ~ Custom built systems for furniture manufacturing
- ~ Scale pan weighing systems
- ~ Waste reclamation systems available
- ~ Wire feed rolls for slickened fiber
- ~ Extended aprons
- ~ Variable speed fan(s)

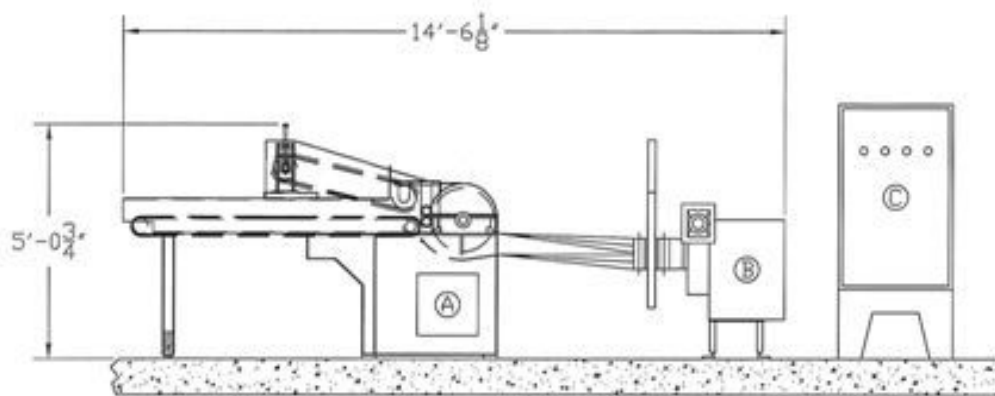

#### Legend

- \*\*\*\*\*
- A - New HWD-36 Opener
- B - New High Speed Fan
- C - New Pillow System Panel

[www.cardclothingservices.com](http://www.cardclothingservices.com)

